

## VARACTOR DIODES

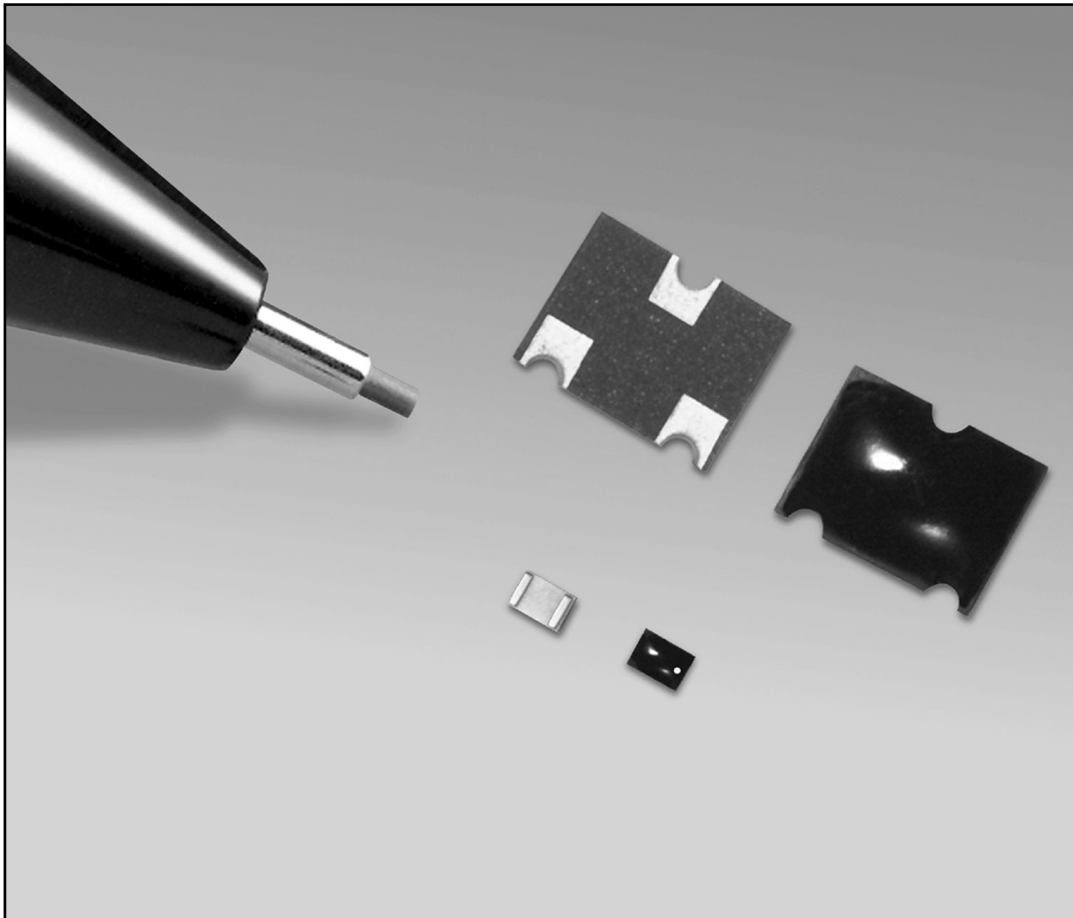

**Sprague-Goodman Electronics, Inc.**

1700 SHAMES DRIVE, WESTBURY, NY 11590  
TEL: 516-334-8700 • FAX: 516-334-8771  
E-MAIL: [info@spraguegoodman.com](mailto:info@spraguegoodman.com)



# SUPER HYPERABRUPT TUNING VARACTOR DIODES

## FEATURES

- Mesa epitaxial silicon construction
- Silicon dioxide passivated
- Superior mid range linear characteristics
- High tuning ratios
- High Q
- Available in common cathode Style
- Available in chip form (add suffix -000)

- Low voltage wireless phase locked loop VCOs
- Phase shifters

## SPECIFICATIONS

Reverse breakdown voltage at 10  $\mu$ A DC (at 25°C): 12 V min

Maximum reverse leakage current at -10 V (at 25°C): 0.05  $\mu$ A DC

Device dissipation at 25°C: 250 mW (derated linearly to zero at +125°C)

Operating junction temperature: -55°C to +125°C

Storage temperature: -55°C to +125°C

## APPLICATIONS

- TCXOs, VCXOs
- Low voltage wireless open loop VCOs

Total Capacitance $C_T$ (pF) at -1 V min max		Capacitance Ratio $\frac{C_T \text{ at } -1 \text{ V}}{C_T \text{ at } -3 \text{ V}}$		Capacitance Ratio $\frac{C_T \text{ at } -1 \text{ V}}{C_T \text{ at } -6 \text{ V}}$		Q min at -4 V (50 MHz)	Model Number	
		min	max	min	max		min	max
3.00	3.60	1.4	1.9	2.6	3.3	1500	GVD20433-001	GVD20433-004
5.85	7.15	1.6	2.0	2.8	3.4	1200	GVD20434-001	GVD20434-004
10.35	12.65	1.6	2.0	2.9	3.4	1000	GVD20435-001	GVD20435-004
15.50	18.50	1.6	2.0	3.0	3.5	900	GVD20436-001	GVD20436-004
45.00	54.00	1.6	2.0	3.0	3.5	750	GVD20437-001	---

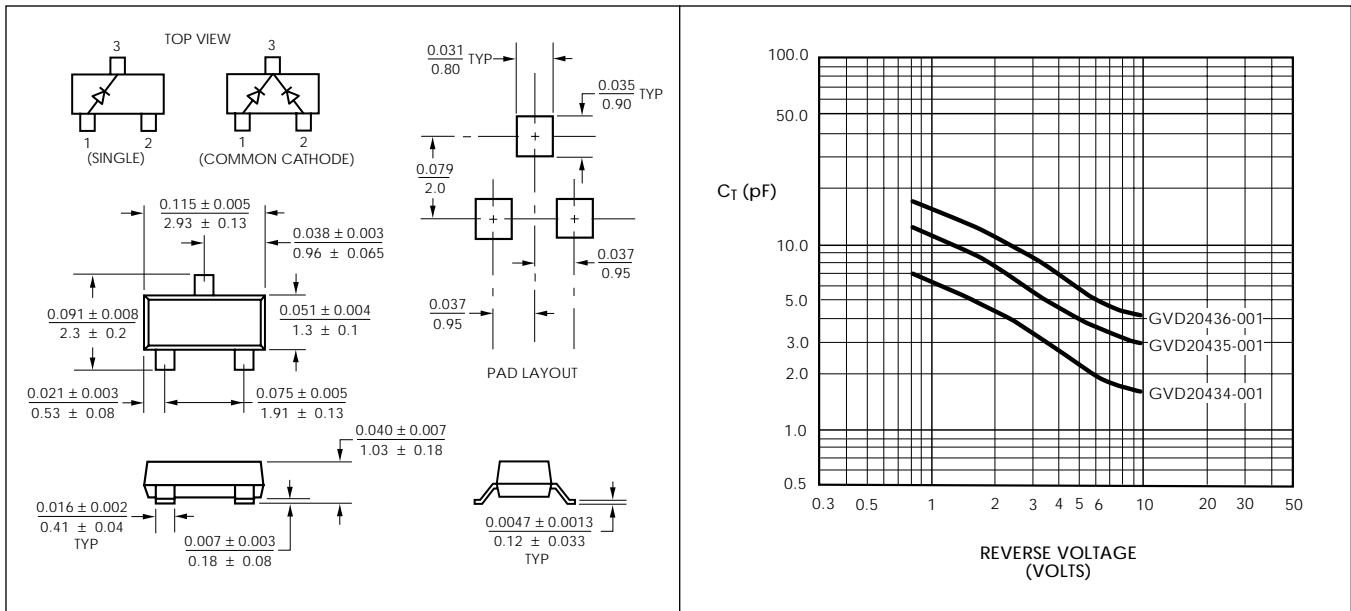

SOT-23 PACKAGE - Consult factory for additional package configurations.  
 All dimensions are in / mm.  
 Unless otherwise specified, the tolerance on dimensions is  $\pm 0.004/0.1$ .

# SUPER HYPERABRUPT TUNING VARACTOR DIODES

## FEATURES

- Mesa epitaxial silicon construction
- Silicon dioxide passivated
- Superior mid range linear characteristics
- High tuning ratios
- High Q
- Available in common cathode style
- Available in chip form (add suffix -000)

## APPLICATIONS

- TCXOs, VCXOs
- Low voltage wireless open loop VCOs

- Low voltage wireless phase locked loop VCOs
- Phase shifters

## SPECIFICATIONS

Reverse breakdown voltage at 10  $\mu$ A DC (at 25°C): 12 V min

Maximum reverse leakage current at -10 V (at 25°C): 0.05  $\mu$ A DC

Device dissipation at 25°C: 250 mW (derated linearly to zero at +125°C)

Operating junction temperature: -55°C to +125°C

Storage temperature: -55°C to +125°C

Total Capacitance $C_T$ (pF) at -1 V min	Total Capacitance $C_T$ (pF) at -2.5 V min max		Total Capacitance $C_T$ (pF) at -8 V max	Q min at -4 V (50 MHz)	Model Number	
	min	max			Single	Common Cathode
13.0	6.5	10.0	2.7	750	GVD20442-001	GVD20442-004
13.0	6.5	10.0	2.7	350	GVD20443-001	GVD20443-004
17.0	8.5	13.0	3.2	600	GVD20444-001	GVD20444-004
17.0	8.5	13.0	3.2	300	GVD20445-001	GVD20445-004
26.0	13.0	20.0	4.7	500	GVD20446-001	---
26.0	13.0	20.0	4.7	225	GVD20447-001	---
36.0	18.0	27.0	6.2	400	GVD20448-001	---
36.0	18.0	27.0	6.2	150	GVD20449-001	---

Total Capacitance $C_T$ (pF) at -1 V min	Total Capacitance $C_T$ (pF) at -2.5 V min max		Total Capacitance $C_T$ (pF) at -4 V max	Q min at -4 V (50 MHz)	Model Number	
	min	max			Single	Common Cathode
9.0	4.5	6.5	3.0	400	GVD20450-001	GVD20450-004

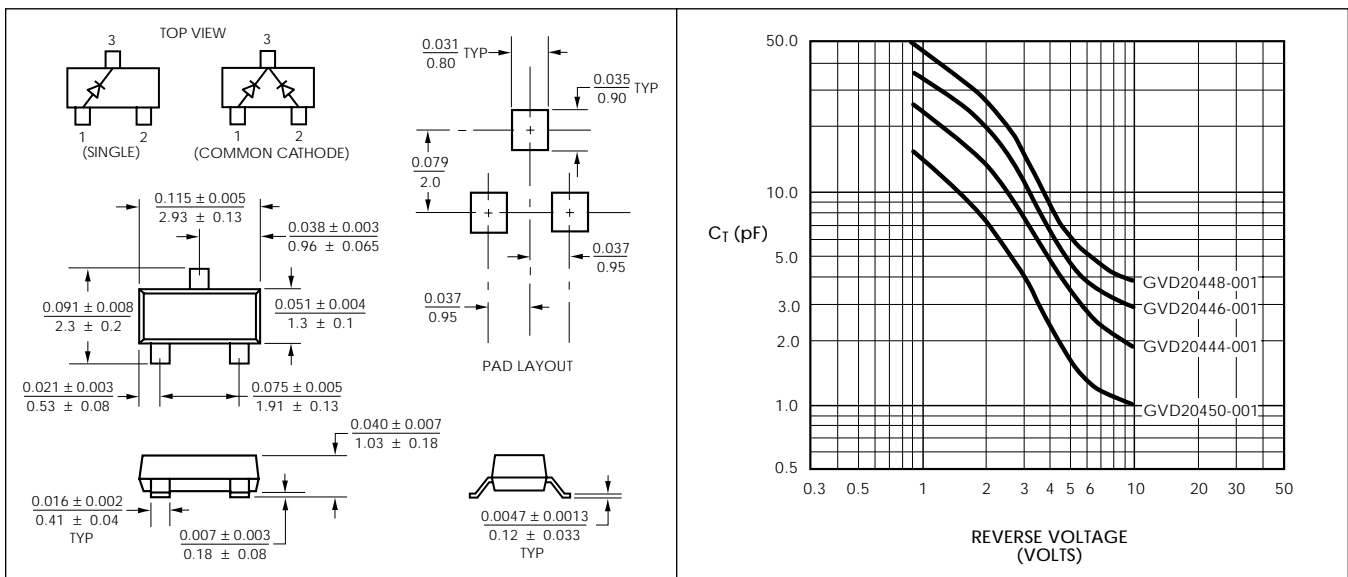

SOT-23 PACKAGE - Consult factory for additional package configurations.

All dimensions are in / mm.

Unless otherwise specified, the tolerance on dimensions is  $\pm 0.004 / 0.1$ .

# SUPER HYPERABRUPT TUNING VARACTOR DIODES

## Surface Mount Low Parasitic Package (SMLP)

### FEATURES

- Mesa epitaxial silicon construction
- Silicon dioxide passivated
- Fits footprint for SOD-323, SOD-123 and smaller
- High frequency (VHF to 8 GHz)
- Available on carrier and reel
- Available in chip form (add suffix -000)
- Two package styles including lower cost, flat top version
- Alternate notched termination version available, contact factory for outline drawing

### APPLICATIONS

- PCS
- WANS
- DECT
- GSM
- TAGS
- AMPS
- Cellular

### SPECIFICATIONS

Reverse breakdown voltage at 10  $\mu$ A DC (at 25°C): 12 V min

Maximum reverse leakage current at -10 V (at 25°C): 0.05  $\mu$ A DC

Device dissipation at 25°C: 250 mW (derated linearly to zero at +125°C)

Operating junction temperature: -65°C to +125°C

Storage temperature: -65°C to +125°C

Total Capacitance $C_T$ (pF) at -1 V min	Total Capacitance $C_T$ (pF) at -2.5 V min max		Total Capacitance $C_T$ (pF) at -4 V max	Total Capacitance $C_T$ (pF) at -8 V max	Q min at -4 V (50 MHz)	Model Number*
36.0	18.0	27.0	12.0	6.2	400	GVD90001 - ---
26.0	13.0	20.0	9.0	4.7	500	GVD90002 - ---
17.0	8.5	13.0	6.0	3.2	600	GVD90003 - ---
13.0	6.5	10.0	4.5	2.7	750	GVD90004 - ---
9.0	4.5	6.5	3.0	1.7	900	GVD90005 - ---
4.0	2.0	3.0	1.5	1.0	1200	GVD90006 - ---
1.8	1.1	1.5	0.8	0.55	1400	GVD90007 - ---
1.2	0.8	1.1	0.6	0.45	1600	GVD90008 - ---
0.6	0.5	0.8	0.4	0.35	1800	GVD90009 - ---

\* For complete model number, select "Dash No.," from chart below.

TERMINATIONS (GOLD PLATED) BOTTOM VIEW D TYP	TOP VIEW DOT INDICATES CATHODE END A	MOUNTING PAD LAYOUT K TYP L M	SIDE VIEW FOR -01 EPOXY ENCAPSULANT C1	SIDE VIEW FOR -11 EPOXY ENCAPSULANT C2	Dash No.	A	B	C <sub>1</sub>	C <sub>2</sub>	D	K	L	M
					-011	0.10	0.050	0.035	0.050	0.015 ± 0.004	0.030	0.070	0.112
-111	2.5	1.3	0.89	1.3	0.38 ± 0.1	0.76	1.8	2.84					
-012	0.12	0.060	0.035	0.050	0.020 ± 0.005	0.030	0.080	0.132					
-112	3.0	1.5	0.89	1.3	0.51 ± 0.1	0.76	2.0	3.35					
-013	0.200	0.100	0.035	0.050	0.020 ± 0.005	0.030	0.120	0.212					
-113	5.08	2.54	0.89	1.3	0.51 ± 0.1	0.76	3.05	5.38					
-014	0.075	0.050	0.035	0.050	0.015 ± 0.004	0.030	0.070	0.087					
-114	1.9	1.3	0.89	1.3	0.38 ± 0.1	0.76	1.8	2.2					
-015	0.062	0.042	0.030	0.050	0.011 ± 0.003	0.020	0.060	0.072					
-115	1.6	1.1	0.76	1.3	0.28 ± 0.08	0.51	1.5	1.8					

All dimensions are in / mm.

Unless otherwise specified, the tolerance on dimensions is ± 0.003/0.08.

Note: An SMLP package with three terminations sized to fit the pad layout for an SOT-23 package is also available. This package can be used for multiple diode designs (such as common cathode or common anode). Contact factory for the three-terminal SMLP outline drawing, and for further information on the multiple diode configurations.

# WIDEBAND HYPERABRUPT TUNING VARACTOR DIODES

## Microwave Hyperabrupt Series

### FEATURES

- Mesa epitaxial silicon construction
- Silicon dioxide passivated
- Superior wide range linear characteristics
- High tuning ratios
- High Q
- Available in common cathode style
- Available in chip form (add suffix -000)

### APPLICATIONS

- Low phase noise VCOs
- Phase locked loop VCOs

- High linearity VCOs
- Phase shifters

### SPECIFICATIONS

Reverse breakdown voltage at 10  $\mu$ A DC (at 25°C): 20 V min

Maximum reverse leakage current at -20 V (at 25°C): 0.05  $\mu$ A DC

Device dissipation at 25°C: 250 mW (derated linearly to zero at +125°C)

Operating junction temperature: -55°C to +125°C

Storage temperature: -55°C to +125°C

Total Capacitance $C_T$ (pF) at -0 V min	Total Capacitance $C_T$ (pF) at -4 V min max		Total Capacitance $C_T$ (pF) at -20 V min max		Q min at -4 V (50 MHz)	Model Number	
						Single	Common Cathode
2.7	1.25	1.75	0.43	0.57	1000	GVD30422-001	GVD30422-004
4.2	1.70	2.50	0.52	0.72	850	GVD30432-001	GVD30432-004
6.3	2.20	3.80	0.68	0.96	700	GVD30442-001	GVD30442-004
11.9	3.70	5.50	0.94	1.30	600	GVD30452-001	GVD30452-004
26.0	9.00	11.00	1.90	2.50	400	GVD30462-001	GVD30462-004

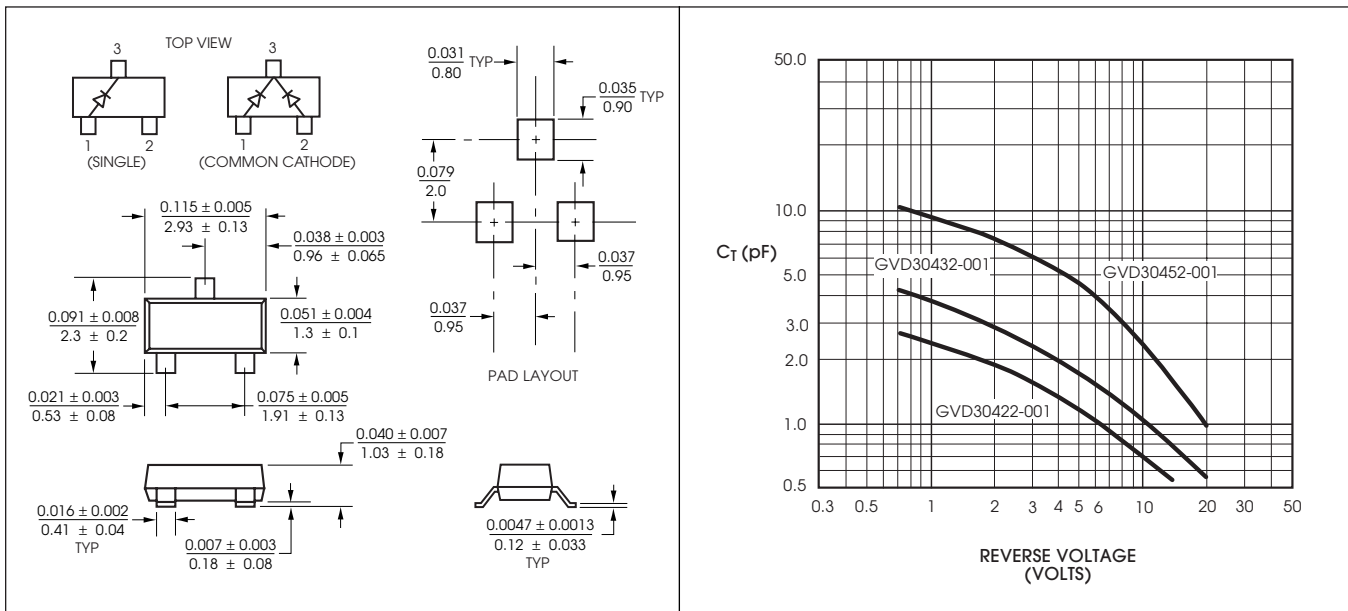

SOT-23 PACKAGE - Consult factory for additional package configurations.  
 All dimensions are in / mm.  
 Unless otherwise specified, the tolerance on dimensions is  $\pm 0.004/0.1$ .





# MICROWAVE HYPERABRUPT TUNING VARACTOR DIODES

## Surface Mount Low Parasitic Package (SMLP)

### FEATURES

- Mesa epitaxial silicon construction
- Silicon dioxide passivated
- Fits Footprint for SOD-323, SOD-123 and smaller
- High frequency (VHF to 8 GHz)
- Available on carrier and reel
- Available in chip form (add suffix -000)
- Two package styles including lower cost, flat top version
- Alternate notched termination version available, contact factory for outline drawing

### APPLICATIONS

- PCS
- WANS
- AMPS
- GSM
- TAGS
- DECT
- Cellular

### SPECIFICATIONS

Reverse breakdown voltage at 10  $\mu$ A DC (at 25°C): 22 V min  
 Maximum reverse leakage current at -20 V (at 25°C): 0.05  $\mu$ A DC  
 Device dissipation at 25°C: 250 mW (derated linearly to zero at +125°C)  
 Operating junction temperature: -65°C to +125°C  
 Storage temperature: -65°C to +125°C

Total Capacitance $C_T$ (pF) at 0 V typical	Total Capacitance $C_T$ (pF) at -4 V		Total Capacitance $C_T$ (pF) at -20 V		Q min at -4 V (50 MHz)	Model Number*
	min	max	min	max		
26.0	8.75	10.80	1.85	2.50	400	GVD92101 - _ _ _
14.0	4.45	5.50	0.85	1.30	600	GVD92102 - _ _ _
7.0	2.65	3.30	0.65	0.90	700	GVD92103 - _ _ _
5.0	1.75	2.20	0.50	0.70	850	GVD92104 - _ _ _
3.0	1.30	1.65	0.40	0.55	1000	GVD92105 - _ _ _
2.0	0.85	1.10	0.30	0.45	1200	GVD92106 - _ _ _

\*For complete model number, select "Dash No." from chart below.

TERMINATIONS (GOLD PLATED) BOTTOM VIEW D TYP	TOP VIEW DOT INDICATES CATHODE END A	SIDE VIEW FOR -01 EPOXY ENCAPSULANT C1	SIDE VIEW FOR -11 EPOXY ENCAPSULANT C2	MOUNTING PAD LAYOUT K TYP, L, M	Dash No.	A	B	C <sub>1</sub>	C <sub>2</sub>	D	K	L	M
					- 011	0.10	0.050	0.035	0.050	0.015 $\pm$ 0.004	0.030	0.070	0.112
- 111	2.5	1.3	0.89	1.3	0.38 $\pm$ 0.1	0.76	1.8	2.84					
- 012	0.12	0.060	0.035	0.050	0.020 $\pm$ 0.005	0.030	0.080	0.132					
- 112	3.0	1.5	0.89	1.3	0.51 $\pm$ 0.1	0.76	2.0	3.35					
- 013	0.200	0.100	0.035	0.050	0.020 $\pm$ 0.005	0.030	0.120	0.212					
- 113	5.08	2.54	0.89	1.3	0.51 $\pm$ 0.1	0.76	3.05	5.38					
- 014	0.075	0.050	0.035	0.050	0.015 $\pm$ 0.004	0.030	0.070	0.087					
- 114	1.9	1.3	0.89	1.3	0.38 $\pm$ 0.1	0.76	1.8	2.2					
- 015	0.062	0.042	0.030	0.050	0.011 $\pm$ 0.003	0.020	0.060	0.072					
- 115	1.6	1.1	0.76	1.3	0.28 $\pm$ 0.08	0.51	1.5	1.8					

All dimensions are in / mm.  
 Unless otherwise specified, the tolerance on dimensions is  $\pm$  0.003/0.08.

Note: An SMLP package with three terminations sized to fit the pad layout for an SOT-23 package is also available. This package can be used for multiple diode designs (such as common cathode or common anode). Contact factory for the three-terminal SMLP outline drawing, and for further information on the multiple diode configurations.

# HIGH Q ABRUPT TUNING VARACTOR DIODES

## FEATURES

- Mesa epitaxial silicon construction
- Silicon dioxide passivated
- Economy price
- Mil grade performance
- High Q
- Available in common cathode style
- Available in chip form (add suffix -000)

## APPLICATIONS

- Low phase noise VCOs

- Phase locked loop VCOs
- Moderate bandwidth VCOs

## SPECIFICATIONS

Reverse breakdown voltage at 10  $\mu$ A DC (at 25°C): 30 V min

Maximum reverse leakage current at -25 V (at 25°C): 0.05  $\mu$ A DC

Device dissipation at 25°C: 250 mW (derated linearly to zero at +125°C)

Operating junction temperature: -55°C to +125°C

Storage temperature: -55°C to +125°C

Total Capacitance $C_T$ (pF) at -4 V ( $\pm 10\%$ )	Capacitance Ratio $C_T$ at 0 V $C_T$ at -30 V min	Q min at -4 V (50 MHz)	Model Number	
			Single	Common Cathode
1.2	3.4	3200	GVD1202-001	GVD1202-004
1.5	3.5	3000	GVD1203-001	GVD1203-004
1.8	3.5	3000	GVD1204-001	GVD1204-004
2.2	3.7	3000	GVD1205-001	GVD1205-004
2.7	3.7	2500	GVD1206-001	GVD1206-004
3.3	3.8	2500	GVD1207-001	GVD1207-004
3.9	3.9	2500	GVD1208-001	GVD1208-004
4.7	3.9	2000	GVD1209-001	GVD1209-004
5.6	4.0	2000	GVD1210-001	GVD1210-004
6.8	4.0	2000	GVD1211-001	GVD1211-004
8.2	4.0	2000	GVD1212-001	GVD1212-004
10.0	4.1	1800	GVD1213-001	GVD1213-004
12.0	4.1	1600	GVD1214-001	GVD1214-004
15.0	4.2	1250	GVD1215-001	GVD1215-004
18.0	4.2	1000	GVD1216-001	GVD1216-004
22.0	4.2	850	GVD1217-001	GVD1217-004

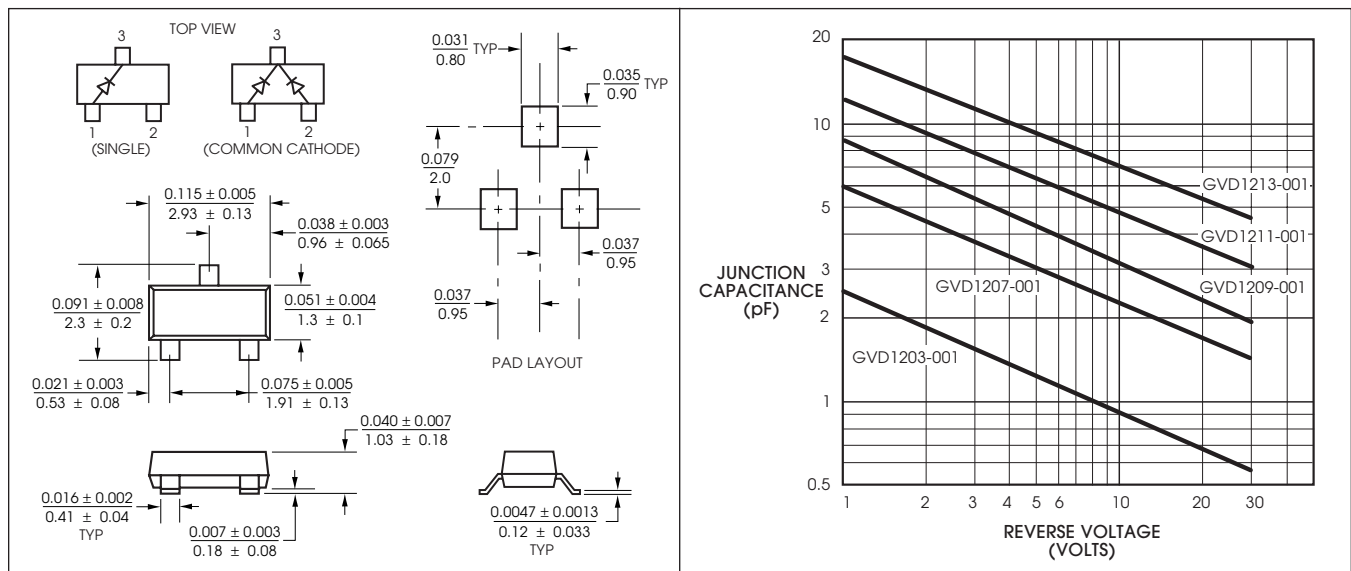

SOT-23 PACKAGE - Consult factory for additional package configurations.  
 All dimensions are in / mm.  
 Unless otherwise specified, the tolerance on dimensions is  $\pm 0.004/0.1$ .

# MICROWAVE ABRUPT TUNING VARACTOR DIODES

## Surface Mount Low Parasitic Package (SMLP)

### FEATURES

- Mesa epitaxial silicon construction
- Silicon dioxide passivated
- Fits Footprint for SOD-323, SOD-123 and smaller
- High Frequency (VHF to 8 GHz)
- Available on carrier and reel
- Available in chip form (add suffix -000)
- Two package styles including lower cost, flat top version
- Alternate notched termination version available, contact factory for outline drawing

### APPLICATIONS

- PCS
- WANS
- AMPS
- GSM
- TAGS
- DECT
- Cellular

### SPECIFICATIONS

Reverse breakdown voltage at 10  $\mu$ A DC (at 25°C): 30 V min

Maximum reverse leakage current at -25 V (at 25°C): 0.05  $\mu$ A DC

Device dissipation at 25°C: 250 mW (derated linearly to zero at +125°C)

Operating junction temperature: -65°C to +125°C

Storage temperature: -65°C to +125°C

Total Capacitance $C_T$ (pF) at -4 V ( $\pm 10\%$ )	Capacitance Ratio $\frac{C_T \text{ at } 0 \text{ V}}{C_T \text{ at } -4 \text{ V}}$ min	Capacitance Ratio $\frac{C_T \text{ at } -4 \text{ V}}{C_T \text{ at } -30 \text{ V}}$ min	Q min at -4 V (50 MHz)	Model Number*
0.8	1.5	1.45	3900	GVD91300 - ----
1.0	1.6	1.55	3800	GVD91301 - ----
1.2	1.7	1.60	3700	GVD91302 - ----
1.5	1.8	1.65	3600	GVD91303 - ----
1.8	1.9	1.70	3500	GVD91304 - ----
2.2	2.0	1.75	3400	GVD91305 - ----
2.7	2.0	1.80	3300	GVD91306 - ----
3.3	2.1	1.85	3100	GVD91307 - ----
3.9	2.1	1.90	2700	GVD91308 - ----
4.7	2.2	1.95	2600	GVD91309 - ----
5.6	2.2	2.00	2500	GVD91310 - ----

\*For complete model number, select "Dash No." from chart below.

Dash No.	A	B	C <sub>1</sub>	C <sub>2</sub>	D	K	L	M
- 011	0.10	0.050	0.035	0.050	0.015 $\pm$ 0.004	0.030	0.070	0.112
- 111	2.5	1.3	0.89	1.3	0.38 $\pm$ 0.1	0.76	1.8	2.84
- 012	0.12	0.060	0.035	0.050	0.020 $\pm$ 0.005	0.030	0.080	0.132
- 112	3.0	1.5	0.89	1.3	0.51 $\pm$ 0.1	0.76	2.0	3.35
- 013	0.200	0.100	0.035	0.050	0.020 $\pm$ 0.005	0.030	0.120	0.212
- 113	5.08	2.54	0.89	1.3	0.51 $\pm$ 0.1	0.76	3.05	5.38
- 014	0.075	0.050	0.035	0.050	0.015 $\pm$ 0.004	0.030	0.070	0.087
- 114	1.9	1.3	0.89	1.3	0.38 $\pm$ 0.1	0.76	1.8	2.2
- 015	0.062	0.042	0.030	0.050	0.011 $\pm$ 0.003	0.020	0.060	0.072
- 115	1.6	1.1	0.76	1.3	0.28 $\pm$ 0.08	0.51	1.5	1.8

All dimensions are in / mm. Unless otherwise specified, the tolerance on dimensions is  $\pm 0.003/0.08$ .  
 Note: An SMLP package with three terminations sized to fit the pad layout for an SOT-23 package is also available. This package can be used for multiple diode designs (such as common cathode or common anode). Contact factory for the three-terminal SMLP outline drawing, and for further information on the multiple diode configurations.

# MINIATURE MICROWAVE SILICON VARACTOR DIODES

## Surface Mount Monolithic Package (SMMP)

### FEATURES

- Multilayer construction
- Low SMT profile
- Low series inductance
- Low parasitic capacitance (0.06 pF)
- High Q
- Available on carrier and reel

### APPLICATIONS

Microwave Voltage Controlled Oscillators (VCOs)  
Ideal for Wide Bandwidth Applications (VHF-10 GHz)

### SPECIFICATIONS

Reverse breakdown voltage at 10  $\mu$ A DC  
(at 25°C): See below

Maximum reverse leakage current at -10 V  
(at 25°C): 0.05  $\mu$ A DC

Operating junction temperature: -65°C to +125°C

Storage temperature: -65°C to +125°C

Total Capacitance $C_T$ (pF) at -1 V		Capacitance Ratio $\frac{C_T \text{ at } -1 \text{ V}}{C_T \text{ at } -3 \text{ V}}$		Capacitance Ratio $\frac{C_T \text{ at } -1 \text{ V}}{C_T \text{ at } -6 \text{ V}}$		Q min at -4 V (50 MHz)	Model Number
min	max	min	max	min	max		
2.6	3.8	1.4	2.2	2.6	3.6	1500	GVD60100

Reverse breakdown voltage at 10  $\mu$ A DC: 15 V min

Total Capacitance $C_T$ (pF) at -0 V typical	Total Capacitance $C_T$ (pF) at -4 V		Total Capacitance $C_T$ (pF) at -20 V		Q min at -4 V (50 MHz)	Model Number
	min	max	max	max		
3.25	0.9	1.5	0.2	0.45	1000	GVD60200

Reverse breakdown voltage at 10  $\mu$ A DC: 22 V min

Models shown above supplied bulk in vials.  
For 300 pc gel pack, add "-03" to the model number.  
For 5000 pc carrier and reel, add "-50" to the model number.

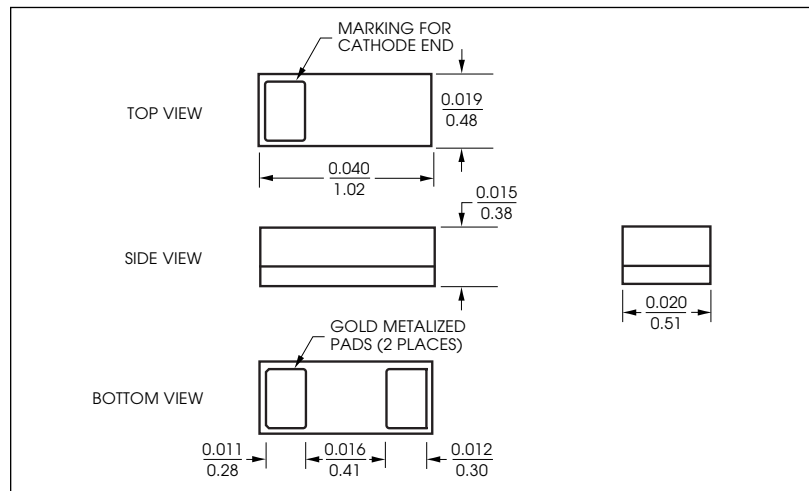

All dimensions are in / mm.  
Unless otherwise specified, the tolerance on dimensions is  $\pm 0.004 / 0.1$ .